



Volvo Construction Equipment

L60H, L70H, L90H

VOLVO WHEEL LOADER 11.0-17.3 t 167-186 hp



A passion for performance.

At Volvo Construction Equipment, we're not just coming along for the ride. Developing products and services that raise productivity – we are confident we can lower costs and increase profits for industry experts. Part of the Volvo Group, we are passionate about innovative solutions to help you work smarter – not harder.

Helping you to do more.

Doing more with less is a trademark of Volvo Construction Equipment. High productivity has long been married to low energy consumption, ease of use and durability. When it comes to lowering life-cycle costs, Volvo is in a class of its own.

Designed to fit your needs.

There is a lot riding on creating solutions that are suited to the particular needs of different industry applications. Innovation often involves high technology – but it doesn't always have to. Some of our best ideas have been simple, based on a clear and deep understanding of our customers' working lives.



You learn a lot in 180 years.

Over the years, Volvo has advanced solutions that have revolutionized the use of construction equipment. No other name speaks Safety louder than Volvo. Protecting operators, those around them and minimizing our environmental impact are traditional values that continue to shape our product design philosophy.

We're on your side.

We back the Volvo brand with the best people. Volvo is truly a global enterprise, one that is on standby to support customers quickly and efficiently – wherever they are.

We have a passion for performance.



Volvo Trucks

Renault Trucks



Mack Trucks



UD Trucks



Volvo Buses



Volvo Construction Equipment



Volvo Penta



Volvo Financial Services

See clearer in comfort.

The Volvo L60H, L70H and L90H wheel loaders are versatile machines that can take on any task with a wide range of perfectly matched attachments. From the comfort of your wheel loader, sit back and enjoy a clear view of the site while increasing your productivity and uptime.

HMI – New display and controls

Operator ergonomics is at the forefront of Volvo's HMI (Human Machine Interface) design. The information display, controls, setting switches, hydraulic control levers and steering wheel, are all designed and placed in the cab for easy and comfortable operation. The information display informs the operator about all necessary machine information for peace of mind, control and less fatigue. The new display has better visibility even when exposed to direct sunlight.



Seat

The operator's seat has several adjustment possibilities for maximum comfort. Suspension and damping are adjustable according to body weight and both the seat cushion and backrest can be positioned at various angles. Well placed instruments and adjustable lever console make your long day a lot more comfortable.



Heating, ventilation and air conditioning

The standard Automatic Heat Control (AHC) system ensures a comfortable environment inside the cab. Air conditioning is also available so the operator can work in comfortable conditions, in any climate.



Industry leading air-filtration

Volvo's industry-leading air filtration system allows 90% of the cab air to be recirculated through the main filter for continuous dust removal and a cleaner environment. The cab air intake is located in a high position where the air is cleaner. An easily replaceable external pre-filter effectively separates coarser dust and particles before entering the main filter and cab.



Cab

Volvo continues to provide the industry-leading cab for maximum comfort, visibility and productivity. The cab is consistent across all Volvo wheel loaders and boasts unparalleled all-round visibility, space, climate control, safety and vibration levels. The Volvo cab is also renowned for its effective sound proofing, protecting the operator from noise for a more productive environment.



TP linkage

The TP linkage combined with the new and improved Volvo attachment bracket offers industry leading versatility and unparalleled front visibility. The TP linkage combines the benefits of the Z-bar and parallel linkage to deliver high breakout torque and excellent parallel movement throughout the entire lifting range. The bracket allows attachments to be changed quickly and safely so the machine can perform a wide range of tasks.

An upfront approach.

The wheel loaders are especially designed to match a number of attachments so that you can handle a variety of tasks on your jobsite with the same machine. The TP linkage together with the improved Volvo attachment bracket provides excellent versatility and visibility.

Attachment Bracket

Want to switch between different attachments quickly and easily? Then look no further than the market-leading attachment bracket from Volvo Construction Equipment. The smart design of the interface enables safe connection to a wide range of attachments that meet the International Standardization Organization (ISO) standard.



Double sealed joints

The Volvo TP linkage features double sealed joints for all linkage pins. The double sealing system retains lubricating grease and prevents dust or other contaminants from getting in. The double sealing system results in a longer life for the lift arm system. The high quality and durable components last longer, reduce maintenance and increase uptime.



Roll back angle

The Volvo TP linkage geometry, along with the Volvo bucket design, provides excellent bucket roll-back angles. The superior roll-back angle increases the amount of retained material in the bucket and keeps the load closer to the front axle for increased stability and less spillage. As a result, the roll back angle increases productivity.



Parallel movement

The TP linkage allows excellent parallel movement, which means the load stays level throughout the entire lifting range. This allows the operator to have full control over the load, which increases safety and productivity.

A multiple of talents.

Volvo offers the most durable and effective Volvo attachments, which work in harmony with your machine for increased productivity and versatility. They are designed for improved visibility and ease of use, so you can swap and change your Volvo attachments quickly and safely.

New General Purpose (GP) bucket

The improved Volvo general purpose bucket is designed for higher productivity and increased fuel efficiency. The bucket – when fitted with bolt-on edges – handles loose material, such as gravel and aggregates in both short cycle or load and carry operations. It can be fitted with optional welded teeth and segments to load harder banked material with ease. It provides excellent support on your jobsite and the wear resistant steel is used in the most exposed areas for increased durability and long life.



Pallet forks

Volvo's pallet fork frame with pallet fork tines allow the machine to handle, load and move pallets of building material, drainage pipe, lumber, or loose items around the uneven terrain of a construction site. The Volvo pallet fork and attachment bracket has been designed for industry-leading visibility at different working heights while moving and lifting materials. Volvo's durable TP linkage, attachment bracket and pallet forks increase safety.



Material handling arm

Volvo's material handling arm extends your machine's versatility. Designed to work with Volvo wheel loaders and with an approved lift capacity set for each arm and machine, you'll know exactly how much you can lift safely. The extendable arm consists of three sections, providing increased flexibility and greater reach. Safety Mechanical stops also prevent the material handling arm from overextending – a safety hook at the end of the arm is fitted as standard.



Light Material (LM) bucket

The Volvo light material bucket with a robust light weight design and high capacity, secures the highest productivity for your machine. The bucket is designed for efficient handling low density material, such as snow, sawdust, woodchips and compost. It's delivered with a standard bolt-on edge.



Attachment offer

Volvo attachments give you more flexibility. Each attachment from the extensive range is perfectly matched to the machine's link-arm geometry and breakout, rim pull and lifting force. All attachments can be fastened and removed quickly thanks to Volvo's attachment bracket so you can 'connect and go'.

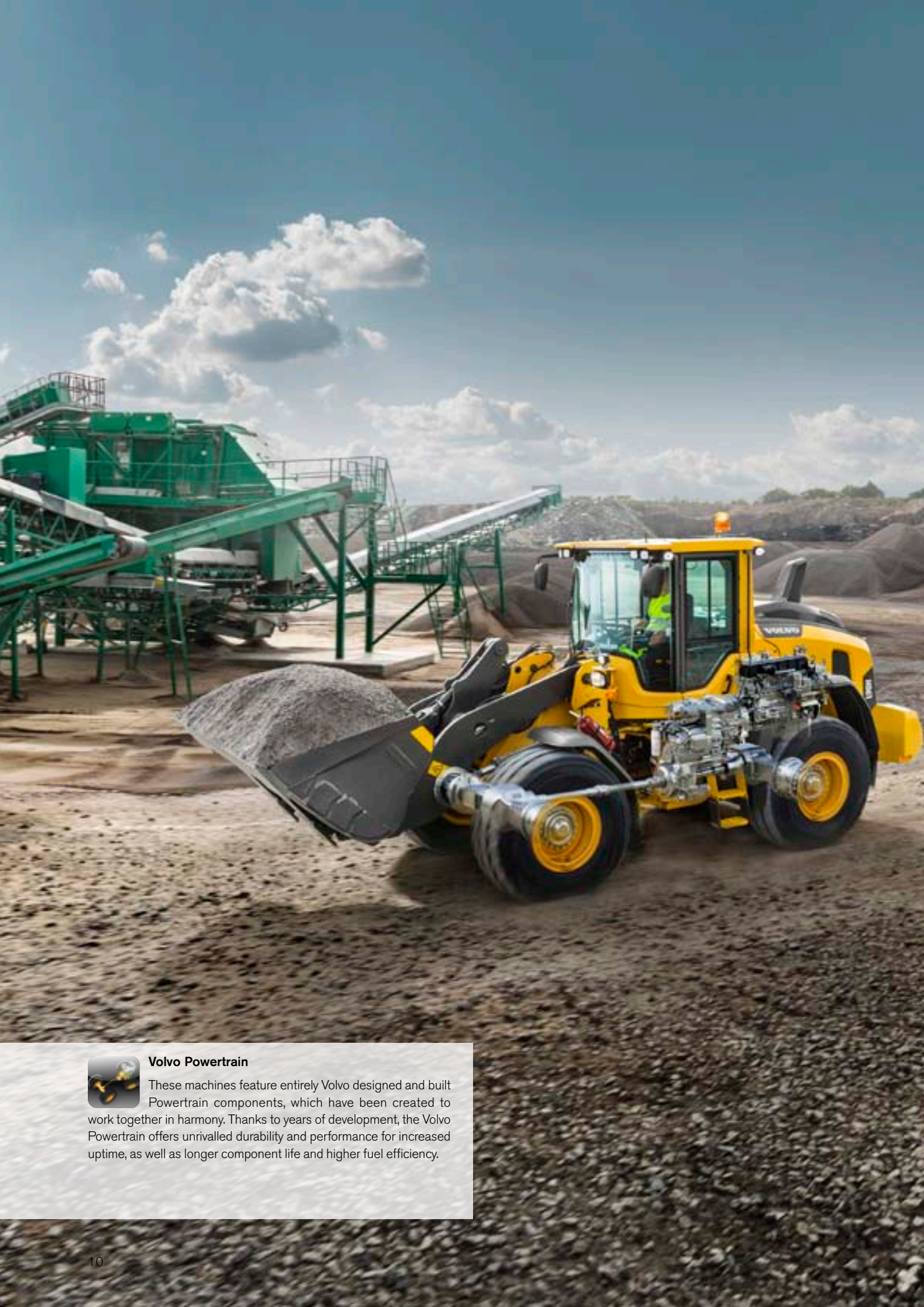

Volvo Powertrain

These machines feature entirely Volvo designed and built Powertrain components, which have been created to work together in harmony. Thanks to years of development, the Volvo Powertrain offers unrivalled durability and performance for increased uptime, as well as longer component life and higher fuel efficiency.

Made to last.

Quality is key at Volvo, which is why only the best components, technology and systems are used in the Volvo wheel loaders. All parts work with each other for increased reliability and a long cycle life, saving you long term costs and downtime.

Counter shaft transmission

The Volvo counter shaft transmission offers a heavy duty solution for proven reliability and durability. The machines are equipped with a counter shaft transmission that can endure more stress. Various tailored settings can be selected by the operator to match all applications whether it's short cycle truck loading or medium to long distance load and carry.



Axles

Volvo axles provide longer service life as a result of the free-floating shaft design, durable components, circulating lubrication oil and wet-disc brakes. The outboard service brakes are easily maintained for greater uptime and can also be easily monitored using the brake wear indicators.



Differential lock

The differential lock provide outstanding traction and rimpull on soft and slippery ground conditions. The front axle is mounted to the front frame and equipped with an electro-hydraulically operated differential lock. The differential lock is a dog-clutch type which can secure 100% locking, which minimizes wheel spin and tire wear.



Intelligent hydraulic system

The load sensing hydraulic system increases fuel efficiency and provides perfect control of the load. It also allows for more engine power to be available for rimpull, providing easier penetration for increased performance. With help from the variable displacement piston pumps and precision control levers, hydraulic power is delivered according to demand.

Strongly attached.

Environmental care is at the forefront of Volvo's core values and to show its passion and dedication, Volvo thinks about all aspects of the machine which can impact on the environment.

Tier 4 Final/Stage IV engine

Volvo's 6 litre diesel Tier 4 Final/ Stage IV engine complies with the latest emissions legislation and delivers high torque at low engine rpm. The engine delivers industry-leading performance and impressive fuel efficiency.



Eco-pedal

This unique feature keeps operators aware of whether they are operating in the most economical way in order to increase fuel efficiency. The Eco-pedal with a mechanical push-back mechanism engages when the engine rpm is about to exceed the economic operating range. The operator senses the resistance and then operates within the optimal operating range. If full engine speed is needed, this mechanical push-back mechanism can easily be overridden.



Service access

The service friendly design keeps your routine maintenance quick and efficient. The one piece motorised engine hood opens up at a large angle, providing full access to the engine compartment and engine maintenance points are strategically grouped together for quick and easy service checks. The machine also features fluid drain ports which simplifies the oil changing. This prevents oil spillages that impacts the environment.



95% of the machine is recyclable

Planned recycling of the machine is the last stage of its life cycle. Being able to recycle machine parts and materials for use in new Volvo wheel loaders or other products is part of Volvo's responsibility to environmental care. According to our calculations, the machine is up to 95% recyclable by weight. Volvo thrives to build a sustainable environment and reuse parts whenever possible.

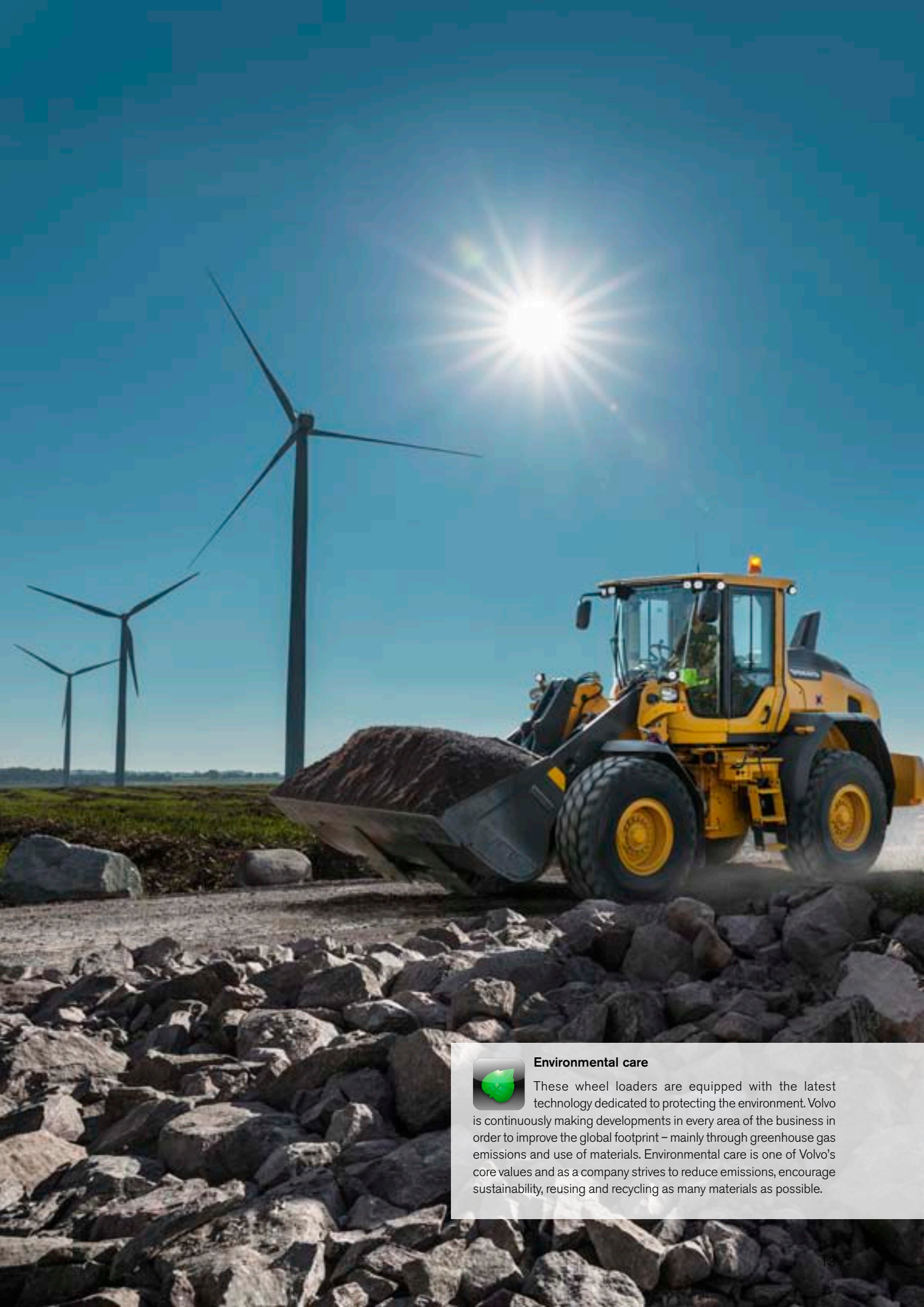

Environmental care

These wheel loaders are equipped with the latest technology dedicated to protecting the environment. Volvo is continuously making developments in every area of the business in order to improve the global footprint – mainly through greenhouse gas emissions and use of materials. Environmental care is one of Volvo's core values and as a company strives to reduce emissions, encourage sustainability, reusing and recycling as many materials as possible.

An application for any occasion.



Cab

Volvo continues to provide the industry-leading cab for maximum comfort, visibility and productivity.

Human Machine Interface

The information display, controls, setting switches, hydraulic control levers and steering wheel, are all designed and placed in the cab for easy and comfortable operation.



TP linkage

The TP linkage combines the benefits of Z-bar and parallel linkage in one to deliver high breakout torque and excellent parallel movement through the entire lifting range.

Attachment bracket

The Volvo attachment bracket is the most commonly used attachment bracket in the world with a compact and robust design for outstanding visibility.



Attachment offer

Volvo's wide range of high quality attachments are perfectly matched to the machine's linkage, hydraulics and driveline to work as one unit and increase productivity.

Eco pedal

This unique feature keeps operators aware of whether they are operating in the most economical way in order to increase fuel efficiency.



Volvo Powertrain

These machines feature entirely Volvo designed and built Powertrain components, which have been created to work together in harmony.

Hydraulic cooling fan

Hydraulically driven, electronically controlled cooling fan, located between the engine and radiator, speeds-up only when necessary to lower fuel consumption and sound levels.

Tier 4 Final/Stage IV engine technology

Volvo's 6 litre diesel Tier 4 Final/ Stage IV engine complies with the latest emissions legislation and delivers high torque at low engine rpm.

Intelligent hydraulic system

The load sensing hydraulic system increases fuel efficiency and provides perfect control of the load.

Service access

The service friendly design increases your uptime by allowing easy access and quick service.

CareTrack*

CareTrack provides information for better planning and smarter working, including fuel consumption reports, location reports and service reminders.



Environmental care

The wheel loaders are equipped with the latest technology dedicated to protecting the environment.

* In markets where CareTrack is available

Volvo L60H, L70H, L90H in detail.

Engine

6-cylinder, 6 liters inline turbocharged diesel engine with an advanced fuel injection system with the common rail. Fuel is distributed under high pressure from a high-pressure accumulator, the rail. One belt driven high pressure pump deliver the fuel to the rail and then further on via high-pressure pipes to the electronically operated fuel injectors. Engine meets Stage IV emission legislation.

L60H

Engine	D6J (Stage IV)	
Max power at	r/s	23.3 - 30.0
	r/min	1 400 - 1 800
SAE J1995 gross	kW / hp	123 / 167
ISO 9249, SAE J1349 net	kW / hp	123 / 167
Max torque at	r/s	23.3
	r/min	1 400
SAE J1995 gross	Nm	820
ISO 9249, SAE J1349	Nm	820
Economic working range	r/s	13.3 - 26.6
	r/min	800 - 1 600
Displacement	l	5.7

L70H

Engine	D6J (Stage IV)	
Max power at	r/s	23.3 - 28.3
	r/min	1 400 - 1 700
SAE J1995 gross	kW / hp	127 / 173
ISO 9249, SAE J1349 net	kW / hp	127 / 173
Max torque at	r/s	23.3
	r/min	1 400
SAE J1995 gross	Nm	853
ISO 9249, SAE J1349 net	Nm	853
Economic working range	r/s	13.3 - 26.6
	r/min	800 - 1 600
Displacement	l	5.7

L90H

Engine	D6J (Stage IV)	
Max power at	r/s	23.3 - 31.7
	r/min	1 400 - 1 900
SAE J1995 gross	kW / hp	137 / 186
ISO 9249, SAE J1349 net	kW / hp	137 / 186
Max torque at	r/s	23.3
	r/min	1 400
SAE J1995 gross	Nm	934
ISO 9249, SAE J1349 net	Nm	934
Economic working range	r/s	13.3 - 26.6
	r/min	800 - 1 600
Displacement	l	5.7

L60H

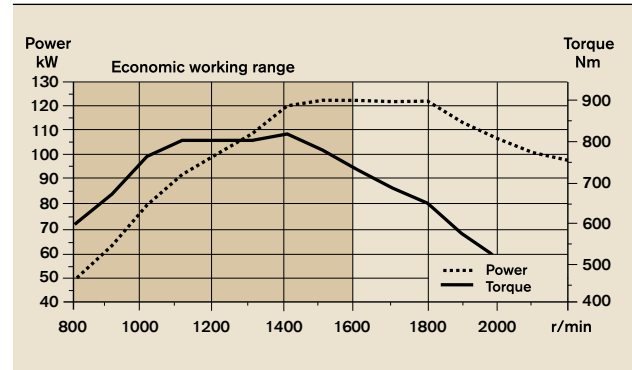

L70H

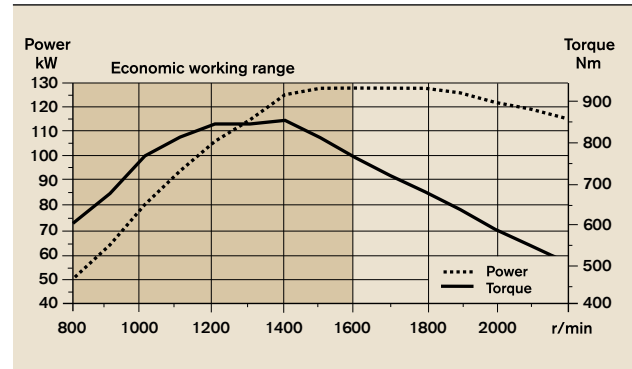

L90H

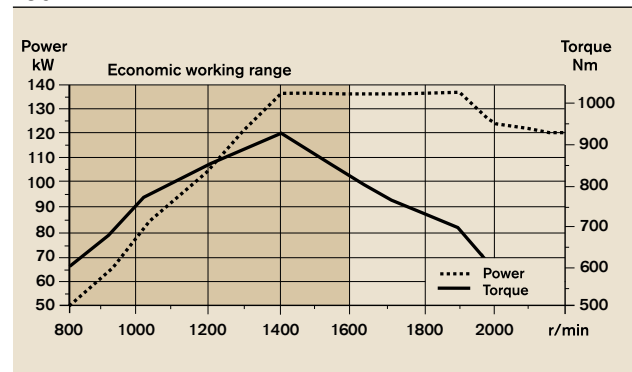

Drivetrain

Torque converter: Single-stage

Transmission: Volvo countershaft transmission with single lever control. Fast and smooth shifting of gears with Pulse Width Modulation (PWM) valve.

Transmission: Volvo Automatic Power Shift (APS) gear shifting system with fully automatic shifting 1-4 and mode selector with 4 different gear shifting programs, including AUTO mode.

Axles: Volvo fully floating axle shafts with planetary hub reductions and cast steel axle housing. Fixed front axle and oscillating rear axle. 100% differential lock on the front axle.

L60H

Transmission		Volvo	HTE 125
Torque multiplication, stall ratio			2,5:1
Maximum speed, forward/reverse	1st gear	km/h	7
	2nd gear	km/h	14
	3rd gear	km/h	27
	4th gear*	km/h	44
Measured with tires			20.5R25
Front axle/rear axle			AWB 15/AWB 15
Rear axle oscillation		°	± 13
Ground clearance at 13° osc.		mm	470

L70H

Transmission		Volvo	HTE 125
Torque multiplication			2,5:1
Maximum speed, forward/reverse	1st gear	km/h	7
	2nd gear	km/h	14
	3rd gear	km/h	27
	4th gear*	km/h	44
Measured with tires			20.5R25
Front axle/rear axle			AWB 25/AWB 20
Rear axle oscillation		°	± 13
Ground clearance at 13° osc.		mm	470

L90H

Transmission		Volvo	HTE 125
Torque multiplication			2,5:1
Maximum speed, forward/reverse	1st gear	km/h	7
	2nd gear	km/h	13
	3rd gear	km/h	25
	4th gear*	km/h	44
Measured with tires			20.5R25
Front axle/rear axle			AWB 25/AWB 20
Rear axle oscillation		°	± 13
Ground clearance at 13° osc.		mm	470

* limited by ECU

Electrical system

Contronic electrical system with central warning light and buzzer for following functions: - Serious engine fault, Low

steering system pressure, Over speed warning engine, Interruption in communication (computer fault), Central warning light and buzzer with the gear engaged for the following functions: Low engine oil pressure, High engine oil temperature, High charge air temperature, Low coolant level, High coolant temperature, High crank case pressure, Low transmission oil pressure, High transmission oil temperature, Low brake pressure, Engaged parking brake, Fault on brake charging, Low hydraulic oil level, High hydraulic oil temperature, Overspeeding in engaged gear, High brake cooling oil temperature front and rear axles, etc.

L60H, L70H, L90H

Batteries	V	2 x 12
Battery capacity	Ah	2 x 110
Cold cranking capacity, approx	A	680
Alternator rating	W/A	3135/80
Starter motor output	kW	5,5

Brake system

Service brake: Volvo dual-circuit system with outboard mounted, hydraulically operated, fully sealed and circulating oil cooled wet disc brakes. Operator selectable, four transmission declutch settings while braking.

Parking brake: Dry disc brake mounted on the transmission output shaft. Applied by spring force, electro-hydraulically released with a switch on the instrument panel.

Secondary brake: Dual brake circuits with rechargeable accumulators.

Standard: The brake system complies with the requirements of ISO 3450, 71/320/EEC

L60H

Number of brake discs per wheel		1
Accumulators	l	3 x 0,5

L70H

Number of brake discs per wheel		1
Accumulators	l	2 x 0,5+1 x 1,0

L90H

Number of brake discs per wheel		1
Accumulators	l	2 x 0,5+1 x 1,0

Volvo L60H, L70H, L90H in detail.

Cab

Instrumentation: All important information is centrally located in the operator's field of vision. Display for Contronic monitoring system
Heater and defroster: Heater coil with filtered fresh air and fan with auto and 11 manual speed settings. Defroster vents for all window areas.
Operator's seat: Operator's seat with adjustable air suspension and retractable seatbelt. The seat is mounted on a bracket on the rear cab wall and floor. The forces from the retractable seatbelt are absorbed by the seat rails.
Standards: The cab is tested and approved according to ROPS (ISO 3471), FOPS (ISO 3449). The cab meets with requirements according to ISO 6055 (Operator overhead protection - Industrial trucks) and SAE J386 (Operator Restraint System).

L60H

Emergency exit: Use emergency hammer to break window			
Sound level in cab			
ISO 6396/SAE J2105	dB(A)		68
External sound level			
ISO 6395/SAE J2104	dB(A)		104
Ventilation	m ³ /min		9
Heating capacity	kW		16
Air conditioning (optional)	kW		7.5

L70H

Emergency exit: Use emergency hammer to break window			
Sound level in cab			
ISO 6396/SAE J2105	dB(A)		68
External sound level according to			
ISO 6395/SAE J2104	dB(A)		105
Ventilation	m ³ /min		9
Heating capacity	kW		16
Air conditioning (optional)	kW		7.5

L90H

Emergency exit: Use emergency hammer to break window			
Sound level in cab			
ISO 6396/SAE J2105	dB(A)		68
External sound level			
ISO 6395/SAE J2104	dB(A)		105
Ventilation	m ³ /min		9
Heating capacity	kW		16
Air conditioning (optional)	kW		7.5

Lift arm system

Torque parallel linkage (TP-linkage) with high breakout torque and parallel lift-arm action.

L60H

Lift cylinders		2	2	2
Cylinder bore	mm	110	110	120
Piston rod diameter	mm	70	70	70
Stroke	mm	665	756	733
Tilt cylinder		1	1	1
Cylinder bore	mm	150	160	180
Piston rod diameter	mm	80	90	90
Stroke	mm	444	432	430

Hydraulic system

Closed center load sensing hydraulic system with non pressurised hydraulic tank and pilot operated control valves.

System supply: Variable displacement axial piston pump supply the hydraulic system.

Valves: The central valve distributes pressure and flow out to the cooling fan, steering, brake, pilot and hydraulic system. Steering system gets priority over others.

Lift function: The valve has four positions; raise, hold, lower and float position. Automatic boom kickout position can be set to any position between maximum reach and full lifting height.

Tilt function: The valve has three functions; rollback, hold and dump. Automatic tilt-back can be adjusted to the desired bucket angle.

Cylinders: Double-acting cylinders for all functions.

Filter: Full flow filtration through 10 micron (absolute) filter cartridge.

		L60H	L70H	L90H
Working pressure maximum, pump 2 for steering-, brake-, pilot- and working hydraulic system	MPa	26	26	31
Flow	l/min	145	154	171
at	MPa	10	10	10
engine speed	r/s(r/min)	1 900	1 900	1 900
Working pressure maximum, pump 3 for brake- and cooling fan system	MPa	21	21	21
Flow	l/min	33	33	33
at	MPa	10	10	10
engine speed	r/s(r/min)	1 900	1 900	1 900
Pilot system, working pressure	MPa	3.5	3.5	3.5
Cycle times				
Lift	s	4.5	5.1	5.4
Tilt	s	2.3	1.3	1.9
Lower, empty	s	2.9	2.7	3.2
Total cycle time	s	9.7	9.1	10.5

Steering system

System supply: The steering system has priority feed from a load-sensing axial piston pump with variable displacement.

Steering cylinders: Two double-acting cylinders.

		L60H	L70H	L90H
Steering cylinders		2	2	2
Cylinder bore	mm	70	70	80
Rod diameter	mm	45	45	50
Stroke	mm	386	386	345
Working pressure	MPa	21	21	21
Maximum flow	l/min	60	60	60
Maximum articulation	±°	40	40	40

Service

Service accessibility: Large, electrically operated easy-to-open hood covering whole engine compartment. Fluid filters and component breather air filters are located from ground level access and promote long service intervals. Machine conronics have possibility to monitor, log and analyze data to facilitate troubleshooting.

		L60H	L70H	L90H
Fuel tank (usage)	l	222	222	222
Urea tank	l	20	20	20
Engine coolant	l	30	30	30
Hydraulic oil (tank)	l	90	90	90
Transmission oil	l	21	21	21
Engine oil (refil)	l	19,5	19,5	19,5
Axle oil front	l	25	35	35
Axle oil rear	l	25	27	27

Specifications.

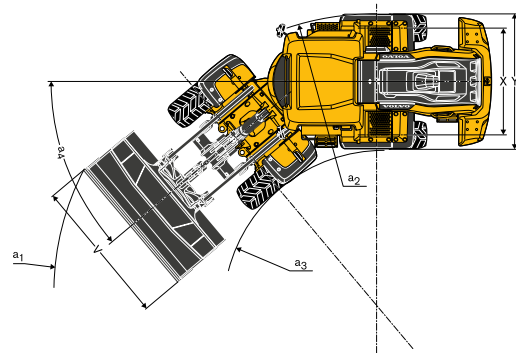
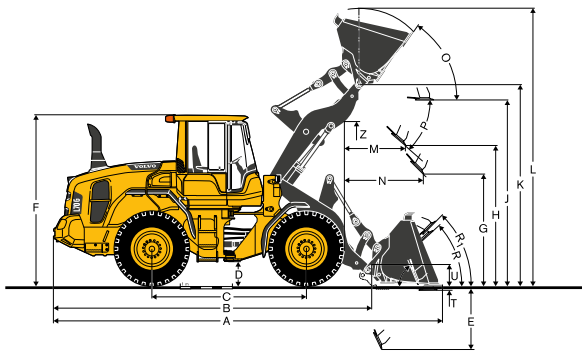

Tires 20.5 R25 L3

		L60H	L70H	L90H	L60H	L70H	L90H
		Standard boom			Long boom		
B	mm	6 040	6 080	6 160	6 550	6 560	6 590
C	mm	3 000	3 000	3 050	3 000	3 000	3 050
D	mm	440	450	450	440	450	450
F	mm	3 270	3 280	3 280	3 270	3 280	3 280
G	mm	2 134	2 134	2 132	2 134	2 134	2 132
J	mm	3 570	3 590	3 660	4 150	4 100	4 090
K	mm	3 870	3 870	3 970	4 380	4 390	4 400
O	°	56	56	57	58	52	57
P _{max}	°	46	46	44	42	43	45
R	°	43	43	44	43	43	46
R1*	°	47	48	49	50	49	51
S	°	79	68	67	78	73	66
T	mm	103	101	107	79	107	102
U	mm	450	440	470	540	500	510
X	mm	1 900	1 930	1 960	1 900	1 930	1 960
Y	mm	2 430	2 460	2 490	2 430	2 460	2 490
Z	mm	3 210	3 160	3 290	3 590	3 500	3 660
a ₂	mm	5 340	5 350	5 430	5 340	5 350	5 430
a ₃	mm	2 900	2 890	2 950	2 900	2 890	2 950
a ₄	±°	40	40	40	40	40	40

* Carry position SAE

Where applicable, specifications and dimensions are according to ISO 7131, SAE J732, ISO 7546, SAE J742, ISO 14397, SAE J818

Tires: 20.5R25 L3

		L60H	L70H	L90H
SAE-Load	kg	3 450	3 990	4 600
Operating weight without load*	kg	12 380	14 110	16 100
Grapple sales code		82194	80153	80832
A	m ²	1.3	1.5	2.4
B	mm	3 410	3 380	3 420
C	mm	1 480	1 590	1 790
D	mm	2 930	2 870	2 790
E	mm	1 170	1 260	1 410
F	mm	1 530	1 510	1 440
G	mm	2 350	2 440	2 740
H	mm	4 330	4 380	4 540
I	mm	5 880	6 030	6 590
J	mm	2 000	2 140	2 790
K	mm	2 080	2 370	2 990
L	mm	1 710	1 790	2 130
M	mm	7 890	7 990	8 460

* Including logging counterweight

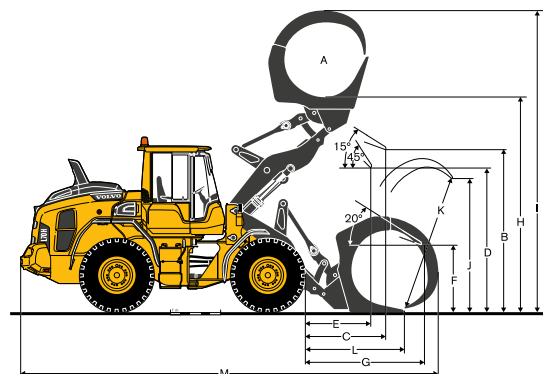

Specifications.

Tires: 20.5R25 L3

		L60H	L70H	L90H
MHA sales code		92 007	92 007	92 008
A*	kg	1 800	2 150	2 760
B*	kg	1 400	1 710	2 130
C*	kg	1 150	1 400	1 740
Static tipping load, straight	kg	3 070	3 430	4 080
35deg. Turn	kg	2 760	3 090	3 650
at full turn	kg	2 670	2 980	3 520
D	mm	2 590	2 710	2 610
E	mm	2 000	2 100	2 010
F	mm	1 460	1 540	1 410
G	mm	3 270	3 320	3 250
H	mm	4 300	4 350	4 380
I	mm	5 430	5 490	5 520
J	mm	900	1 260	1 340
K	mm	1 220	1 740	1 890
L	mm	1 580	2 260	2 430
M	mm	2 260	2 170	2 040
N	mm	3 240	3 090	3 030
O	mm	4 320	4 100	4 020
P	mm	1 510	1 530	1 530
Q	mm	5 290	5 300	5 340
R	mm	6 170	6 180	6 300
S	mm	7 140	7 130	7 260
Operating weight without load	Kg	11 670	13 160	14 520

* Op. load at full turn + tipping position
Tipping loads calculated for max. arm length

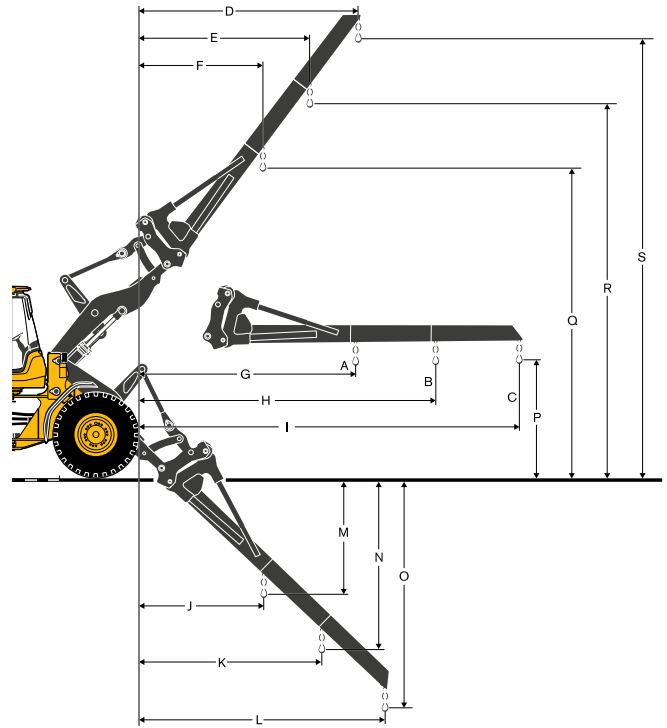

Tires: 20.5R25 L3

		L60H	L70H	L90H
Fork frame sales code		83768	83769	83770
Fork tines sales code (R/L)		80042/80043	80042/80044	80106/80107
Static tipping load, straight	kg	6 570	7 250	8 470
35deg. Turn	kg	5 900	6 510	7 550
at full turn	kg	5 710	6 300	7 280
at load center distance*	mm	600	600	600
A	mm	790	840	930
B	mm	1 560	1 610	1 670
C	mm	-37	-55	-8
D	mm	1 830	1 860	1 800
E	mm	3 710	3 740	3 780
F	mm	700	760	730
Operating weight without load	kg	11 750	13 240	14 610

* Firm and level ground

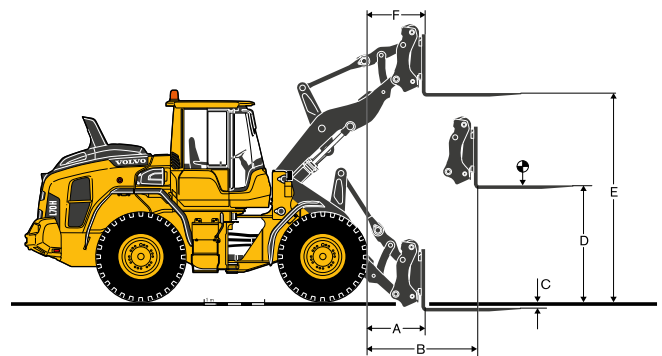

L60H

Tires 20.5R25 XHA2 L3		GENERAL PURPOSE					GRADING	LIGHT MATERIAL		Long Boom	
		1.9 m³ STE H BOE	1.8 m³ STE H T	2.1 m³ STE P BOE	2.1 m³ STE H BOE	2.3 m³ STE P BOE	2.3 m³ STE H BOE	1.7 m³ GRB H BOE	3.1 m³ LM H	5 m³ LM H	
Volume, heaped ISO/SAE	m³	1.9	1.8	2.1	2.1	2.3	2.3	1.7	3.1	5	-
Volume at 110% fill factor	m³	2.1	2	2.3	2.3	2.5	2.5	1.9	3.4	5.5	-
Static tipping load, straight	kg	8 460	8 630	8 820	8 370	8 740	8 290	7 320	7 990	7 970	-1 710
at 35° turn	kg	7 560	7 720	7 900	7 470	7 820	7 390	6 540	7 110	7 070	-1 570
at full turn	kg	7 290	7 450	7 630	7 210	7 550	7 120	6 310	6 860	6 810	-1 540
Breakout force	kN	81.9	83.9	84.9	78.5	80.9	75.1	60.2	61.7	53.8	2
A	mm	7 350	7 380	7 310	7 410	7 370	7 470	7 690	7 720	7 940	520
E	mm	1 120	1 140	1 080	1 180	1 140	1 230	1 400	1 480	1 700	30
H	mm	2 830	3 040	2 840	2 790	2800	2 750	2 510	2 570	2 430	540
L	mm	5 020	5 020	4 800	5 100	5 120	5 170	4 520	5 280	5 480	520
M	mm	1 050	1 400	990	1 090	1 040	1 130	1 130	1 310	1 500	0
N	mm	1 570	2 030	1 560	1 590	1 580	1 600	1 480	1 620	1 670	450
V	mm	2 500	2500	2500	2 500	2 500	2 500	2 500	2 550	2 650	0
a1 clearance circle	mm	11 570	11 620	11 580	11 600	11 610	11 620	11 970	11 840	12 060	440
Operating weight	kg	12 100	12 040	11 870	12 150	11 900	12 200	12 040	12 230	12 520	120

Bucket Selection Chart

The chosen bucket is determined by the density of the material and the expected bucket fill factor. The actual bucket volume is often larger than the rated capacity, due to the features of the TP linkage, including an open bucket design, good rollback angles in all positions and good bucket filling performance. The example represents a standard boom configuration.
 Example: Sand and gravel. Fill factor ~ 105%. Density 1.65 t/m³.
 Result: The 1.9 m³ bucket carries 2.0 m³. For optimal stability always consult the bucket selection chart.

Material	Bucket fill, %	Material density, t/m³	ISO/SAE bucket volume, m³	Actual volume, m³
Earth/Clay	~ 110	~ 1.55	1.9	2.1
		~ 1.40	2.1	2.3
		~ 1.30	2.3	2.5
Sand/Gravel	~ 105	~ 1.65	1.9	2.0
		~ 1.50	2.1	2.2
		~ 1.35	2.3	2.1
Aggregate	~ 100	~ 1.75	1.9	1.9
		~ 1.55	2.1	2.1
		~ 1.55	2.3	2.3
Rock	≤100	~ 1.70	1.7	1.7

The size of rock buckets is optimized for optimal penetration and filling capability rather than the density of the material.

Supplemental Operating Data

Standard boom				
Tires 20.5 R25 L2	17.5 R25 L2	600/65 R25	600/65 R25	
Width over tires	mm	-122	+10	+100
Ground clearance	mm	-72	-10	-30
Tipping load, full turn	kg	-328	-120	-20
Operating weight	kg	-589	-90	+30



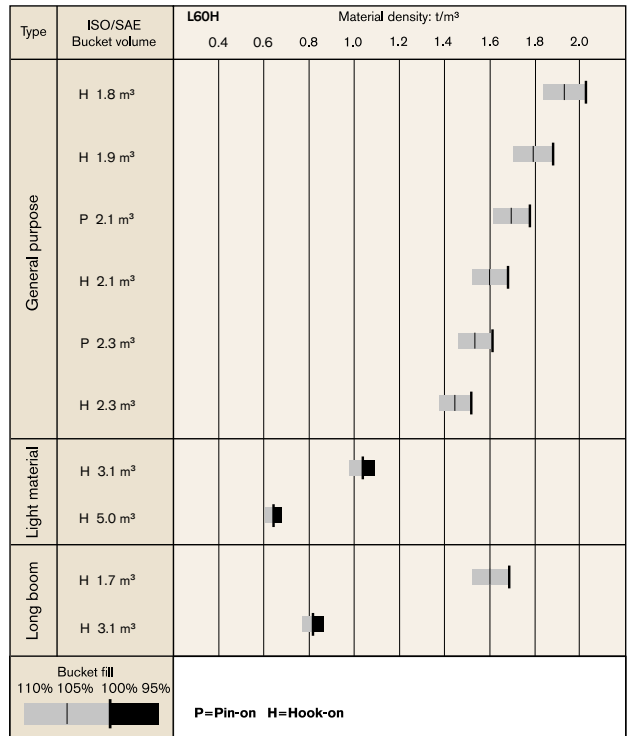





Calculated with 2.1 m³ STE H BOE



How to read bucket fill factor

Specifications.

L70H

Tires 20.5R25 XHA2 L3		GENERAL PURPOSE						GRADING	LIGHT MATERIAL		Long Boom
											
		2.1 m³ STE H BOE	2 m³ STE H T	2.3 m³ STE P BOE	2.3 m³ STE H BOE	2.4 m³ STE P BOE	2.4 m³ STE H BOE	2.2 m³ GRB H BOE	3.4 m³ LM H	6.4 m³ LM H	
Volume, heaped ISO/SAE	m³	2.1	2	2.3	2.3	2.4	2.4	2.2	3.4	6.4	-
Volume at 110% fill factor	m³	2.3	2.2	2.5	2.5	2.6	2.6	2.4	3.7	7	-
Static tipping load, straight	kg	9 330	9 520	9 860	9 270	9 830	9 230	7 550	8 820	8 380	-1 740
at 35° turn	kg	8 340	8 520	8 840	8 280	8 800	8 240	6 700	7 850	7 390	-1 600
at full turn	kg	8 040	8 230	8 540	7 980	8 500	7 950	6 460	7 570	7 090	-1 550
Breakout force	kN	92.8	94.8	98.8	89.4	96.5	87.6	62.7	71.7	53.9	-1.7
A	mm	7 440	7 590	7 370	7 490	7 400	7 520	7 950	7 780	8 330	460
E	mm	1 150	1 290	1 080	1 190	1 110	1 220	1 670	1 470	1 970	20
H	mm	2 780	2 690	2 830	2 750	2 810	2 730	2 350	2 530	2 150	560
L	mm	5 100	5 150	5 090	5 170	5 130	5 200	4 720	5 450	5 790	510
M	mm	1 110	1 240	1 060	1 140	1 070	1 160	1 350	1 340	1 720	-60
N	mm	1 630	1 710	1 610	1 650	1 610	1 660	1 570	1 680	1 720	400
V	mm	2 650	2 500	2 650	2 650	2 650	2 650	2 650	2 650	2 750	0
a1 clearance circle	mm	11 760	11 710	11 740	11 790	11 740	11 800	12 320	11 980	12 410	390
Operating weight	kg	13 700	13 610	13 450	13 730	13 470	13 750	13 990	13 940	14 480	190

Bucket Selection Chart

The chosen bucket is determined by the density of the material and the expected bucket fill factor. The actual bucket volume is often larger than the rated capacity, due to the features of the TP linkage, including an open bucket design, good rollback angles in all positions and good bucket filling performance. The example represents a standard boom configuration. Example: Sand and gravel. Fill factor ~ 105%. Density 1.65 t/m³. Result: The 1.9 m³ bucket carries 2.0 m³. For optimal stability always consult the bucket selection chart.

Material	Bucket fill, %	Material density, t/m³	ISO/SAE bucket volume, m³	Actual volume, m³
Earth/Clay	~ 110	~ 1.55	2.1	2.3
		~ 1.45	2.3	2.6
		~ 1.40	2.4	2.6
Sand/Gravel	~ 105	~ 1.60	2.1	2.2
		~ 1.50	2.3	2.4
		~ 1.45	2.4	2.5
Aggregate	~ 100	~ 1.80	2.1	2.1
		~ 1.70	2.3	2.3
		~ 1.60	2.4	2.4
Rock	≤100	~ 1.70	1.6	1.6

The size of rock buckets is optimized for optimal penetration and filling capability rather than the density of the material.

Supplemental Operating Data

		Standard boom	
Tires 20.5 R25 L2		20.5 R25 L2	600/65 R25
Width over tires	mm	+10	+100
Ground clearance	mm	-20	-30
Tipping load, full turn	kg	-180	-10
Operating weight	kg	-90	+30

Calculated with 2.4 m³ STE H BOE

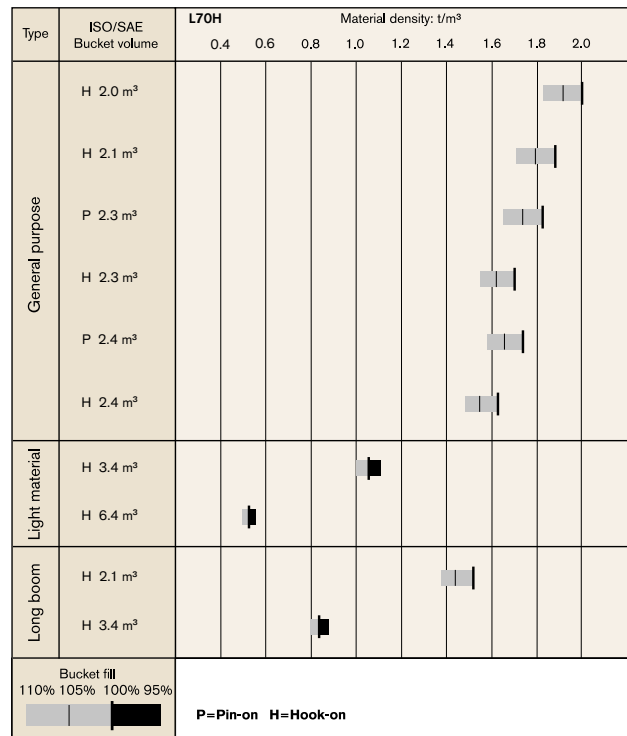

L90H

Tires 20.5R25 XHA2 L3		GENERAL PURPOSE						GRADING	LIGHT MATERIAL		Long Boom
		2.3 m³ STE H BOE	2.5 m³ STE H T	2.5 m³ STE P BOE	2.5 m³ STE H BOE	2.6 m³ STE P BOE	2.8 m³ STE P BOE	2.8 m³ GRB H BOE	4.1 m³ LM H	7 m³ LM H	
Volume, heaped ISO/SAE	m³	2.3	2.5	2.5	2.5	2.6	2.8	2.8	4.1	7	-
Volume at 110% fill factor	m³	2.5	2.8	2.8	2.8	2.9	3.1	3.1	4.5	7.7	-
Static tipping load, straight	kg	10 930	11 090	11 470	10 860	11 430	11 350	10 740	10 240	9 940	-1 680
at 35° turn	kg	9 700	9 850	10 200	9 620	10 160	10 080	9 510	9 030	8 720	-1 530
at full turn	kg	9 330	9 480	9 820	9 260	9 790	9 700	9 150	8 670	8 360	-1 490
Breakout force	kN	138	137.6	145.5	133	142.9	137.7	126.4	100.5	86.9	1.7
A	mm	7 560	7 790	7 510	7 610	7 530	7 580	7 690	8 040	8 340	410
E	mm	1 170	1 370	1 110	1 210	1 140	1 180	1 280	1 590	1 850	-10
H	mm	2 840	2 700	2 880	2 810	2 870	2 830	2 750	2 540	2 340	430
L	mm	5 230	5 320	5 220	5 290	5 250	5 310	5 380	5 570	5 770	420
M	mm	1 070	1 270	1 030	1 110	1 050	1 080	1 140	1 440	1 650	-30
N	mm	1 660	1 760	1 640	1 680	1 640	1 660	1 700	1 710	1 710	360
V	mm	2 750	2 750	2 750	2 750	2 750	2 750	2 750	2 750	3 000	0
a1 clearance circle	mm	12 040	12 170	12 010	12 060	12 020	12 050	12 100	12 300	12 700	310
Operating weight	kg	15 190	15 140	14 980	15 230	15 000	15 050	15 300	15 560	15 990	170

Bucket Selection Chart

The chosen bucket is determined by the density of the material and the expected bucket fill factor. The actual bucket volume is often larger than the rated capacity, due to the features of the TP linkage, including an open bucket design, good rollback angles in all positions and good bucket filling performance. The example represents a standard boom configuration.
 Example: Sand and gravel. Fill factor ~ 105%. Density 1.65 t/m³.
 Result: The 1.9 m³ bucket carries 2.0 m³. For optimal stability always consult the bucket selection chart.

Material	Bucket fill, %	Material density, t/m³	ISO/SAE bucket volume, m³	Actual volume, m³
Earth/Clay	~ 110	~ 1.55	2.1	2.3
		~ 1.45	2.3	2.5
		~ 1.40	2.4	2.6
Sand/Gravel	~ 105	~ 1.60	2.1	2.2
		~ 1.50	2.3	2.4
		~ 1.45	2.4	2.5
Aggregate	~ 100	~ 1.80	2.1	2.1
		~ 1.70	2.3	2.3
		~ 1.60	2.4	2.4
Rock	≤100	~ 1.70	1.6	1.6

The size of rock buckets is optimized for optimal penetration and filling capability rather than the density of the material.

Supplemental Operating Data

		Standard boom		Long boom
Tires 20.5 R25 L2		17.5 R25 L2	600/65 R25	600/65 R25
Width over tires	mm	-130	+60	+60
Ground clearance	mm	-60	-20	-20
Tipping load, full turn	kg	-310	+130	+110
Operating weight	kg	-560	+240	+240

Calculated with 2.8 m³ STE H BOE

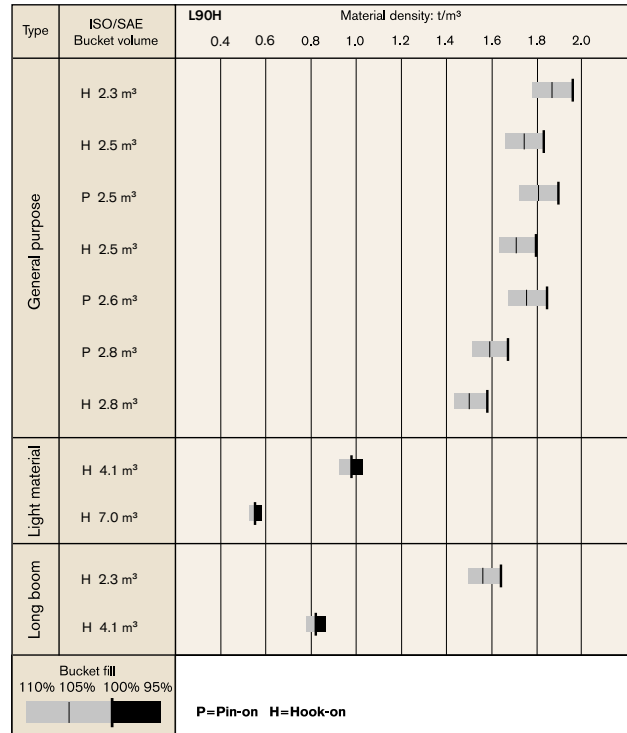

How to read bucket fill factor

Equipment.

STANDARD EQUIPMENT

	L60H	L70H	L90H
Service and maintenance			
Engine oil remote drain and fill	•	•	•
Transmission oil remote drain and fill	•	•	•
Lubrication manifolds, ground accessible	•	•	•
Pressure test ports: transmission and hydraulic, quick connects	•	•	•
Service platforms with anti-slip surfaces	•	•	•
CareTrack	•	•	•
Telematics, 6 -Year Subscription	•	•	•
Toolbox, lockable	•	•	•
Engine			
Exhaust after-treatment system	•	•	•
Three stage air cleaner, pre-cleaner, primary and secondary filter	•	•	•
Indicator glass for coolant level	•	•	•
Preheating of induction air	•	•	•
Fuel pre-filter with water trap	•	•	•
Fuel filter	•	•	•
Crank case breather oil trap	•	•	•
Exhaust heat ventilation	•	•	•
Electrical system			
24 V, pre-wired for optional accessories	•	•	•
Alternator 80A/3135W	•	•	•
Battery disconnect switch	•	•	•
Maintenance free batteries	•	•	•
Battery box, steel	•	•	•
Fuel gauge	•	•	•
Electric horn	•	•	•
Instrument cluster:			
Fuel level	•	•	•
Diesel Exhaust Fluid/AdBlue level	•	•	•
Transmission temperature	•	•	•
Coolant temperature	•	•	•
Instrument lighting	•	•	•
Lighting:			
Twin halogen front headlights with high and low beams	•	•	•
Parking lights	•	•	•
Double brake and tail lights	•	•	•
Turn signals with flashing hazard light function	•	•	•
Halogen work lights (2 front and 2 rear)	•	•	•
Contronic monitoring system			
Contronic display	•	•	•
Fuel consumption	•	•	•
Diesel Exhaust Fluid/AdBlue consumption	•	•	•
Ambient temperature	•	•	•
Clock	•	•	•
Test function for warning and indicator lights	•	•	•
Brake test	•	•	•
Warning and indicator lights:			
Battery charging	•	•	•
Parking brake	•	•	•

	L60H	L70H	L90H
Contronic monitoring system			
Warning and display message:			
Regeneration	•	•	•
Engine coolant temperature	•	•	•
Charge air temperature	•	•	•
Engine oil temperature	•	•	•
Engine oil pressure	•	•	•
Transmission oil temperature	•	•	•
Transmission oil pressure	•	•	•
Hydraulic oil temperature	•	•	•
Brake pressure	•	•	•
Parking brake applied	•	•	•
Brake charging	•	•	•
Overspeed at direction change	•	•	•
Axle oil temperature	•	•	•
Steering pressure	•	•	•
Crank case pressure	•	•	•
Attachment lock open	•	•	•
Level warnings:			
Fuel level	•	•	•
Diesel Exhaust Fluid/AdBlue level	•	•	•
Engine coolant level	•	•	•
Transmission oil level	•	•	•
Hydraulic oil level	•	•	•
Washer fluid level	•	•	•
Engine torque reduction in case of malfunction indication:			
High engine coolant temperature	•	•	•
High engine oil temperature	•	•	•
Low engine oil pressure	•	•	•
High crank case pressure	•	•	•
High charge air temperature	•	•	•
Engine shutdown to idle in case of malfunction indication:			
High transmission oil temperature	•	•	•
Slip in transmission clutches	•	•	•
Key pad, background lit	•	•	•
Start interlock when gear is engaged	•	•	•
Drivetrain			
Automatic Power Shift	•	•	•
Fully automatic gear shifting, 1-4	•	•	•
PWM-controlled gear shifting	•	•	•
Forward and reverse switch by hydraulic lever console	•	•	•
Indicator glass for transmission oil level	•	•	•
Differentials: Front, 100% hydraulic diff lock. Rear, conventional	•	•	•
Tires			
17.5R25	•	•	•
20.5R25	•	•	•
Brake system			
Dual brake circuits	•	•	•
Dual brake pedals	•	•	•
Secondary brake system	•	•	•
Parking brake, electrical-hydraulic	•	•	•
Brake wear indicators	•	•	•
Outboard mounted circulating oil cooled wet disc brakes on all four wheels	•	•	•

STANDARD EQUIPMENT

	L60H	L70H	L90H
Cab			
ROPS (ISO 3471), FOPS (ISO 3449)	•	•	•
Single key kit door/start	•	•	•
Acoustic inner lining	•	•	•
Cigarette lighter, 24 V power outlet	•	•	•
Lockable door	•	•	•
Cab heating with fresh air inlet and defroster	•	•	•
Fresh air inlet with two filters	•	•	•
Automatic heat control	•	•	•
Floor mat	•	•	•
Dual interior lights	•	•	•
Interior rearview mirrors	•	•	•
Dual exterior rearview mirrors	•	•	•
Sliding window, right side	•	•	•
Tinted safety glass	•	•	•
Retractable seatbelt (SAE J386)	•	•	•
Adjustable steering wheel	•	•	•
Storage compartment	•	•	•
Document pocket	•	•	•
Sun visor	•	•	•
Beverage holder	•	•	•
Windshield washer front and rear	•	•	•
Windshield wipers front and rear	•	•	•
Interval function for front and rear wipers	•	•	•
Foot step, left side (toolbox lockable included)	•	•	•
Hydraulic system			
Main valve, double acting 2-spool with hydraulic pilots	•	•	•
Variable displacement axial piston pumps (2) for:			
Working hydraulics, pilot hydraulics, steering system, brakes	•	•	•
Cooling fan, brakes	•	•	•
Hydraulic control levers	•	•	•
Mechanical hydraulic lever lock	•	•	•
Automatic boom kick-out	•	•	•
automatic bucket positioner	•	•	•
Double acting hydraulic cylinders	•	•	•
Indicator glass for hydraulic oil level	•	•	•
Hydraulic oil cooler	•	•	•
External equipment			
Basic fenders, front and rear	•	•	•
Viscous cab mounts	•	•	•
Rubber engine and transmission mounts	•	•	•
Engine hood, electronically openable	•	•	•
Frame, joint lock	•	•	•
Vandalism lock for engine compartment	•	•	•
Lifting eyes	•	•	•
Tie down eyes	•	•	•
Tow hitch	•	•	•
Counterweight, pre drilled for optional guards	•	•	•

Equipment.

OPTIONAL EQUIPMENT

	L60H	L70H	L90H
Service and maintenance			
Automatic lubrication System	•	•	•
Automatic lubrication system for long boom	•	•	•
Oil sampling valve	•	•	•
Refill pump for automatic lubrication system	•	•	•
Grease nipple guards		•	•
Tool kit	•	•	•
Wheel nut wrench kit	•	•	•
Engine			
Air pre-cleaner, cyclone type	•	•	•
Air pre-cleaner, oil-bath type	•	•	•
Air pre-cleaner, turbo type	•	•	•
Engine auto shut down	•	•	•
Engine block heater, 120V / 230V	•	•	•
Fuel heater	•	•	•
Fuel fill strainer	•	•	•
Hand throttle control	•	•	•
Max. fan speed, hot climate	•	•	•
Reversible cooling fan	•	•	•
High altitude kit, 2000m up	•	•	•
Electrical			
Battery disconnect switch	•	•	•
Anti-theft device	•	•	•
Headlights, assym. left	•	•	•
Emergency stop	•	•	•
License plate holder, lighting	•	•	•
Reduced function working lights when reverse gear activated	•	•	•
Side marker lamps	•	•	•
License plate holder, lighting	•	•	•
Forward camera, colour	•	•	•
Rear view camera incl. Monitor, colour	•	•	•
Rear view mirrors, Long arm, right side	•	•	•
Rearview mirrors, adjustable, el. heated	•	•	•
Reverse alarm	•	•	•
Reverse lights	•	•	•
Reversing warning light	•	•	•
Reverse warning light, strobe lightning	•	•	•
Warning, collapsible, rotating beacon	•	•	•
Warning beacon, flashing strobe light	•	•	•
Working lights, attachments	•	•	•
Working lights front, high intensity discharge (HID)	•	•	•
Working lights front, on cab, dual	•	•	•
Working lights rear, on cab	•	•	•
Working lights rear, on cab, dual	•	•	•
Working lights front, extra	•	•	•
Working lights, front on cab, 2 LED lamps	•	•	•
Working lights, rear on cab, 2 LED lamps	•	•	•
Working lights, front on cab, 4 LED lamps	•	•	•
Working lights, rear on cab, 4 LED lamps	•	•	•
Working lights, side on cab, 4 LED lamps	•	•	•
Working lights, rear in grille, 2 LED lamps	•	•	•
Working lights, front above head lamps, 2 LED lamps	•	•	•
Taillight, LED lamp	•	•	•

	L60H	L70H	L90H
Cab			
ACC control panel, with Fahrenheit scale	•	•	•
Anchorage for Operator's manual	•	•	•
Armrest, operator's seat, ISRI, left only	•	•	•
Armrest, operator's seat, Volvo, left	•	•	•
Asbestos dust protection filter	•	•	•
Automatic Climate Control, ACC	•	•	•
Automatic Climate Control, ACC, corr prot. Condenser	•	•	•
Cab air pre-cleaner, cyclone type	•	•	•
Carbon filter - cab	•	•	•
Foot steps, front frame	•	•	•
Remote door opener	•	•	•
Lunch box holder	•	•	•
Operator's seat, Volvo air susp, heavy-duty, high back, heated	•	•	•
Operator's seat, ISRI, air susp, heavy-duty, for CDC	•	•	•
Operator's seat, ISRI, heated, high back	•	•	•
Operator's seat, ISRI, low back	•	•	•
Seatbelt, 3", (width 75 mm)	•	•	•
Radio installation kit incl. 12 volt outlet, left-side	•	•	•
Radio installation kit incl. 12 volt outlet, right-side	•	•	•
Radio installation kit, 12V, for USA	•	•	•
Radio with CD player	•	•	•
Forward view mirror	•	•	•
Rear view mirrors, el.adjusted and heated	•	•	•
Rear view mirrors, long arm right	•	•	•
Rear view mirrors, el.adjusted and heated, long arm right	•	•	•
Steering wheel knob	•	•	•
Sun blinds, rear windows	•	•	•
Sun blinds, side windows	•	•	•
Timer cab heating	•	•	•
Universal door/ignition key	•	•	•
Window, sliding, door	•	•	•
Drivetrain			
Rear axle with limited slip	•	•	•
Speed limiter, 20 km/h (12 mph)	•	•	•
Speed limiter, 30 km/h (19 mph)	•	•	•
Speed limiter, 40 km/h (25 mph)	•	•	•
Brake system			
Stainless steel, brake lines	•	•	•
Parking brake alarm, audible	•	•	•
Hydraulic system			
Arctic kit: Attachment locking, pilot hoses and hydraulic oil	•	•	•
Attachment bracket, cast, visibility-optimized	•	•	•
Attachment bracket, side-tilting	•	•	•
Separate attachment locking, long boom	•	•	•
Separate attachment locking, standard boom	•	•	•
Single acting lifting function	•	•	•
Boom suspension system	•	•	•
HD LS hydraulics, pump kit included		•	
Hydraulic fluid, biodegradable, Volvo	•	•	•
Hydraulic fluid, fire resistant	•	•	•
Hydraulic fluid, for hot climate	•	•	•
Hydraulic function, 3rd	•	•	•
Detent for 3rd hydraulic function	•	•	•
Adjustable flow for 3rd hydraulic function			•
Hydraulic function, 3rd-4th	•	•	•
Single lever control	•	•	•
Single lever control for 3rd hydr. Function	•	•	•

OPTIONAL EQUIPMENT

	L60H	L70H	L90H
External equipment			
Deleted front mudguards	•	•	•
Fire extinguisher	•	•	•
Bracket for fire extinguisher	•	•	•
Fire suppression system	•	•	•
Mudguards, full cover, rear for 80-series tires	•	•	•
Mudflap kit for mudguards, full cover for 80-series tires	•	•	•
Mudguards, full cover, rear and front/rear for 65-series tires	•	•	•
Mudflap kit for mudguards, full cover for 65-series tires	•	•	•
Footsteps front frame	•	•	•
Footsteps, right-hand side	•	•	•
Flexible rear step	•	•	•
Cab ladder, rubber suspended	•	•	•
Protective equipment			
Anti-theft device	•	•	•
Bellyguard front	•	•	•
Bellyguard rear	•	•	•
Boom cylinder hose and tube guards	•	•	•
Cab roof, heavy duty	•	•	•
Center hinge and rear frame guard	•	•	•
Corrosion protection, painting	•	•	•
Cover plate front frame, heavy-duty	•	•	•
Cover plate, under cab	•	•	•
Cover plates rear frame	•	•	•
Guards for front head lights	•	•	•
Guards for grease nipples	•	•	•
Guards for radiator grill	•	•	•
Guards for tail lights, heavy-duty	•	•	•
Wheel/axle seal guards	•	•	•
Window guards, side and rear	•	•	•
Windshield guard	•	•	•

	L60H	L70H	L90H
Other equipment			
CareTrack, GSM/Satellite	•	•	•
CE-marking	•	•	•
Secondary steering	•	•	•
Counterweight, logging	•	•	•
Noise reduction kit, Blauer Engel incl. Decal	•	•	•
Noise reduction kit, EU excl. Decal	•	•	•
Sign, 50 km/h	•	•	•
Sign, slow moving vehicle	•	•	•
Tires and Rims			
17.5R25	•	•	•
20.5R25	•	•	•
600/65R25	•	•	•
650/65R25	•	•	•
Attachments			
Buckets:			
Straight	•	•	•
Spade nose	•	•	•
High tipping	•	•	•
Light material	•	•	•
Grading	•	•	•
Wear parts:			
Bolt-on edge	•	•	•
Bolt-on or weld-on bucket teeth	•	•	•
Segments	•	•	•
Log grapples	•	•	•
Fork equipment	•	•	•
Material handling arm	•	•	•
Snow blade	•	•	•
Broom	•	•	•
Sand spreading bucket	•	•	•
Bale clamp	•	•	•
Drum rotator	•	•	•

SELECTION OF VOLVO OPTIONAL EQUIPMENT

Boom suspension system



3rd and 4th hydraulic function



LED lights



Rear view camera



Reversible fan



Fire suppression system



Not all products are available in all markets. Under our policy of continuous improvement, we reserve the right to change specifications and design without prior notice. The illustrations do not necessarily show the standard version of the machine.



VOLVO

Volvo Construction Equipment

www.volvoce.com